

Solder 02 : R/A version

COMPONENTS

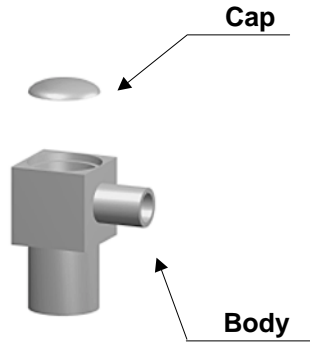

STRIPPING DIMENSIONS

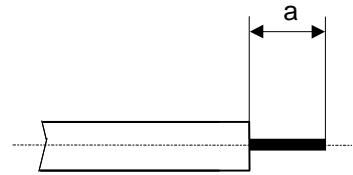

We recommend a cable thermal preconditioning before assembly

1

Insert the cable into the clamping element. Present the pointer in front of the clamping element. Push the cable until it stops, while holding the clamping element pushed on the hollow part of the pointer. Turn the clamping part until the release of the pointer.

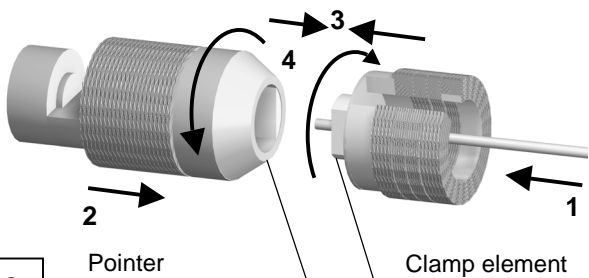

4

Put three rings of solder around the cable. Solder the body onto the cable.

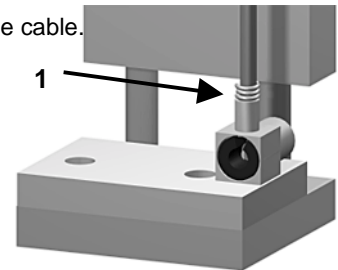

2

Present the cutting element in front of the cutting element. Push and turn both elements, back part opposite to the front part. Once they reach the stop, pull without revolving.

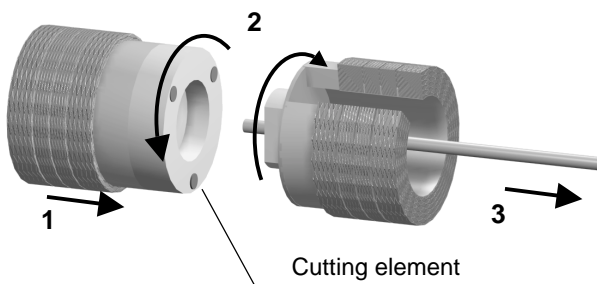

5

After cooling, remove the assembly from the jig. Remove the positioner. Solder the inner conductor.

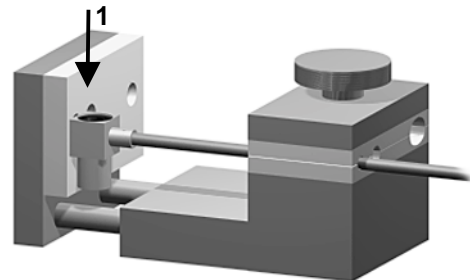

3

Insert the cable into the body. Secure the positioner into the assembly jig. Place the sub-assembly into the assembly jig. Tighten.

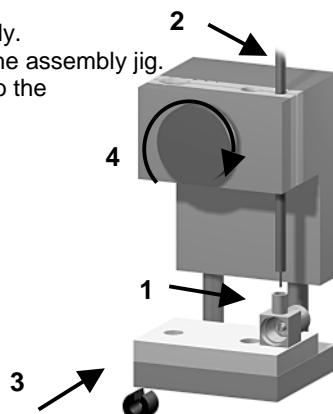

6

Place the cap into the body. Press on the cap flush or slightly below the surface of the body assembly.

